

Dynamic Interaction Analysis of HF Ballasts and Fluorescent Lamps Based on Envelope Simulation

Stanislav Gluzman and Shmuel Ben-Yaakov, *Member, IEEE*

Abstract—A SPICE-compatible simulation methodology for analyzing open- and closed-loop high-frequency electronic ballasts for fluorescent lamp was developed. The proposed procedure applies envelope simulation and makes use of the SPICE-compatible model of a fluorescent lamp. Experimental results validate the reliability of proposed simulation method.

Index Terms—Control, dynamic response, electronic ballasts, envelope simulation, feedback, fluorescent lamps, high-frequency ballasts, SPICE, stability.

I. INTRODUCTION

FLUORESCENT lamps are nonlinear devices that exhibit negative resistance over the useful range of operation. At low frequency, this negative resistance peculiarity is passed through during each period of the ac driving current [1]. When the fluorescent lamp operates at high frequency, the negative resistance is associated with the average power rather than with the instantaneous, cycle by cycle, power [2]. To avoid problems of instability in open-loop operation due to the negative resistance characteristics of the lamp, the driver needs to have a high output impedance [3]. The classical treatment of the problem is normally carried out by examining static V - I plots similar to Fig. 1. Open-loop operation calls for a “current source” driver since a “voltage source” driver will result in unstable operation. At present, commercial electronic ballasts are designed to comply with the “current source” behavior by placing a high impedance element (the ballast) in series with the lamp. The system may include some feedback to stabilize the operating point or to facilitate controlled dimming. This low frequency feedback network is normally designed under the assumption that the lamp can be represented by a resistor when operated at high frequency [2]. This assumption is a good approximation as long as the open-loop system (e.g., ballast and lamp) is stable.

An alternative approach to stabilizing the ballast-lamp system is to obtain the current source behavior by incorporating a wide bandwidth feedback to emulate, in closed loop, a “current source” output characteristic. The advantage of such a solution would be the smaller size of the physical

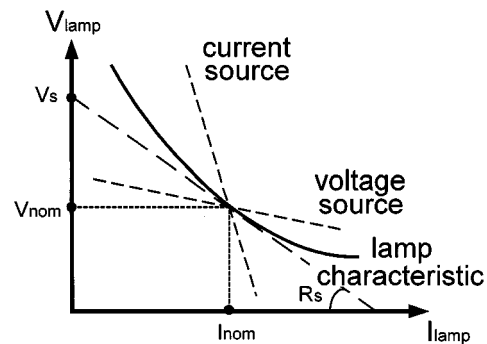

Fig. 1. The static V - I representation of high frequency ballast-lamp system operating in open-loop configuration.

ballasting element (e.g., the series inductor). As the open-loop output impedance of the ballast is decreased, the effect of the incremental impedance of the lamp must be considered [3]–[5]. To handle such cases one would need design tools that can deal with the full dynamic behavior of the ballast-lamp system, including the time dependent response of the lamp. At present, such tools are unavailable. The objective of this paper was to develop a simulation procedure that will enable the examination of ballast-lamp systems over a wide frequency range. Such a tool may conceivably be used to study and design close loop ballast-lamp systems.

II. DYNAMIC PROBLEM

This paper addresses the issue presented schematically in Fig. 2, namely, closed-loop operation of a lamp-ballast system. In the example considered here, an inverter drives a fluorescent lamp. The current of the lamp (after rectification) is used as the output signal of the plant. The objective of the control is to stabilize the current of the lamp. The lamp can be driven by an ac pulsewidth-modulation (PWM) signal that is, in fact, amplitude modulation (AM), or by phase- or frequency-modulated (PM, FM) signals in which the amplitude is kept constant but the frequency is controlled. In the latter cases, the frequency shift will affect the lamp current due to the frequency dependence of the impedance of the series element of the ballast (inductor or capacitor). The key for a successful feedback design of this system is the small-signal response from V_{err} to V_{fb} . This transfer function includes the inverter and the lamp. Considering the fact that the ballast comprises frequency dependent elements and that the lamp is highly nonlinear, analytical derivation of the plant's open-loop transfer function is complex if not impossible with the present level of

Paper MSDAD-S 01-17, presented at the 2000 IEEE Power Electronics Specialist Conference, Galway, Ireland, June 18–23, and approved for publication in the IEEE TRANSACTIONS ON INDUSTRY APPLICATIONS by the Production and Application of Light Committee of the IEEE Industry Applications Society. Manuscript submitted for review June 24, 2000 and released for publication June 26, 2001.

The authors are with the Power Electronics Laboratory, Department of Electrical and Computer Engineering, Ben-Gurion University of the Negev, Beer-Sheva 84105, Israel (e-mail: sby@ee.bgu.ac.il).

Publisher Item Identifier S 0093-9994(01)08324-4.

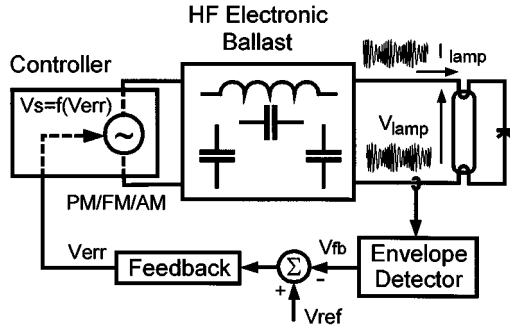

Fig. 2. Electronic ballast for a fluorescent lamp operating in closed loop.

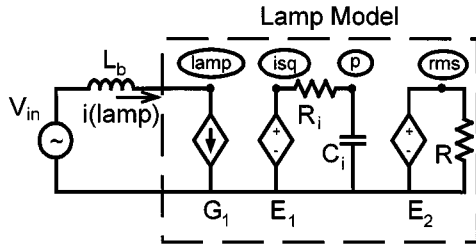

Fig. 3. SPICE-compatible equivalent circuit of a fluorescent lamp.

knowledge. In this paper, we attack the problem of obtaining the small-signal response by SPICE simulation.

III. PROPOSED SIMULATION METHOD

The approach pursued here hinges on two elements: a SPICE-compatible model of the fluorescent lamp [5] and the method of SPICE-compatible envelope simulation [6]. For the sake of completeness we repeat here the fundamentals of these two tools.

A. SPICE Model of Fluorescent Lamp

The equivalent circuit that can be used to emulate the static and dynamic behavior of a fluorescent lamp, when driven at high frequency [5], includes three dependent sources and some passive elements (Fig. 3). This SPICE-compatible model hinges on the fact that the impedance of fluorescent lamps operation at high frequency is approximately resistive and that the resistance is a function of the lamp rms current [2].

The definitions of the dependent sources are thus (per the notation of Fig. 3)

$$E_1 \equiv \{i(\text{lamp})\}^2 \quad (1)$$

$$E_2 \equiv \sqrt{v(p)} \quad (2)$$

$$G_1 \equiv \frac{v(\text{lamp})}{\frac{K_3}{v(\text{rms})} + K_2 + K_1 \cdot v(\text{rms})} \quad (3)$$

where K_1 , K_2 , and K_3 are constants of the lamp.

Note, that here we extend the fitting range of the model by applying a second-order polynomial. This extension was found to emulate the behavior of the lamp over a 1 : 10 dimming range. For such a range, a second-order polynomial fitting seems a better choice [5].

As was shown earlier [5], the small-signal response of this model follows that of the physical lamp. The incremental admittance of the model $Y(f_L)$ as a function of the small-signal frequency (f_L) includes a pole located at the right half of the complex plane and a zero at the left side of the plane [5]:

$$Y_{inc}(f_L) = \frac{1}{R_s} \cdot \frac{\frac{jf_L}{f_0} + 1}{\frac{jf_L}{f_0} \cdot \frac{R_{eq}}{R_s} - 1} \quad (4)$$

where

$$f_0 = \frac{1}{2\pi R_i C_i} \quad (5)$$

$$R_{eq} = K_1 \cdot I_{\text{lamp,rms}} + K_2 + \frac{K_3}{I_{\text{lamp,rms}}} \quad (6)$$

and $I_{\text{lamp,rms}}$ is the rms current of the lamp.

At low frequency ($f_L \rightarrow 0$),

$$Y_{inc} = -\frac{1}{R_s}. \quad (7)$$

This negative resistance explains why the lamp will be unstable when driven by open-loop “voltage source” ballasts [3], [4].

B. SPICE-Compatible Envelope Simulation

The method of envelope simulation [6] follows the concept of the “imaginary resistors” as was discussed in [7]. Any analog modulated signal (AM, FM, or PM) can be described by the following general expression:

$$u(t) = U_1(t) \cdot \cos \omega_c t + U_2(t) \cdot \sin \omega_c t \quad (8)$$

where $U_1(t)$ and $U_2(t)$ are the modulation signals and ω_c is the angular frequency of the carrier.

Expression (8) could also be written as

$$u(t) = \text{Re}[(U_1(t) - j \cdot U_2(t)) \cdot \exp(j\omega_c t)] \quad (9)$$

or as

$$u(t) = |U(t)| \cdot \text{Re}[\exp(\arg(U(t))) \cdot \exp(j\omega_c t)] \quad (10)$$

where $\arg(U(t))$ is $\tan^{-1}(-U_2(t)/U_1(t))$.

Expression (10) implies that the modulated signal in the time domain $u(t)$ can be represented by a generalized phasor that both its magnitude and phase are time dependent. The expression of the complex phasor $\vec{U}(t)$ is

$$\vec{U}(t) = U_1(t) - j \cdot U_2(t). \quad (11)$$

The magnitude

$$|\vec{U}(t)| = \sqrt{\{U_1(t)\}^2 + \{U_2(t)\}^2} \quad (12)$$

is equal to the modulation envelope of the original signal $u(t)$ (10).

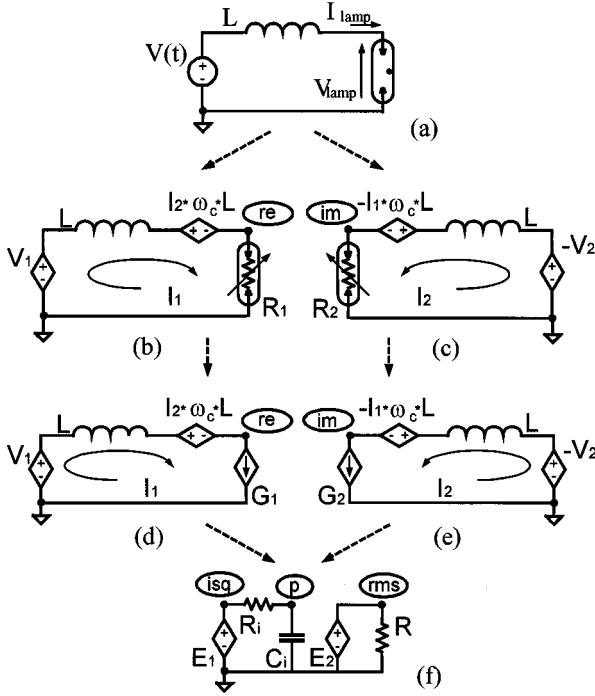

Fig. 4. SPICE-compatible model used to run envelope simulation of a ballast-lamp system.

IV. ENVELOPE SIMULATION OF A BALLAST-LAMP SYSTEM

The envelope simulation procedure is demonstrated by considering simple ballast driving a fluorescent lamp via a series inductor [Fig. 4(a)]. It is assumed that the circuit is driven by a PM-modulated carrier of the form

$$v(t) = A_0 \cdot \cos(2\pi \cdot f_c \cdot t + K_{PM} \cdot \cos(2\pi \cdot f_m \cdot t)). \quad (13)$$

The circuit was transformed according to the guidelines given above, assuming at first that the lamp can be represented by a resistor [Fig. 4(b) and (c)]. The phasor domain sources were

$$V_1 = A_0 \cdot \cos(K_{PM} \cdot \cos(2\pi \cdot f_m \cdot t)) \quad (14)$$

$$V_2 = -A_0 \cdot \sin(K_{PM} \cdot \cos(2\pi \cdot f_m \cdot t)). \quad (15)$$

In the next step, we replace the resistors $R_1 R_2$ that were initially used to represent the lamp [Fig. 4(b) and (c)], by dependent current sources G_1 and G_2 [Fig. 4(d) and (e)], to account for the dependence of the lamp resistance on the rms current of the lamp. The definitions of G_1 and G_2 follow (3):

$$G_1 \equiv \frac{v(\text{re})}{K_1 \cdot v(\text{rms}) + K_2 + \frac{K_3}{v(\text{rms})}} \quad (16)$$

$$G_2 \equiv \frac{v(\text{im})}{K_1 \cdot v(\text{rms}) + K_2 + \frac{K_3}{v(\text{rms})}}. \quad (17)$$

The lamp's model has to be modified now to take into account that the current is broken into the real and imaginary part. Since the resistance of the lamp is a function of the absolute value of the lamp rms current, we define a single additional subcircuit [Fig. 4(f)] to derive the smoothed value of the lamp rms current.

The input to this circuit (E_1) needs to be proportional to the square of the lamp rms current ($i(\text{lamp})$). This can be obtained for the simulation model by adding the contributions of the real and imaginary parts [Fig. 4(d) and (e)] Namely, the output of E_1 (the voltage at node "isq") is defined as

$$v(\text{isq}) \equiv \frac{\{i(G_1)\}^2 + \{i(G_2)\}^2}{2} \quad (18)$$

where $v(\text{isq})$ is the voltage of node "isq" and $i(G_1)$ and $i(G_2)$ are the current through elements G_1 and G_2 , respectively. Notice that dividing by 2 is required to translate the envelope signal (that follows the peaks) to rms values.

Following the explanations given in Section III, it is thus evident that

$$v(\text{rms}) = \sqrt{\frac{1}{T} \int_0^T \frac{\{i(G_1)\}^2 + \{i(G_2)\}^2}{2} dt}. \quad (19)$$

The definitions of the dependent sources are thus [per the notation of Fig. 4(f)]

$$E_1 \equiv \frac{\{i(G_1)\}^2 + \{i(G_2)\}^2}{2} \quad (20)$$

$$E_2 \equiv \sqrt{v(p)}. \quad (21)$$

V. EXAMPLE

For the illustrated case, we chose the carrier frequency ($f_c = \omega_c/2\pi$) to be 28.9 kHz, the modulation parameters: $A_0 = 200$ V, $f_m = 800$ Hz, and $K_{PM} = 6.25$. The simulation was carried out for an OSRAM lamp (L 18 W/10) for which the model parameters were measured to be $K_1 = 51.3$, $K_2 = -81.6$, $K_3 = 75.3$, $R_i = 1$ k Ω , $C_i = 100$ nF.

The circuit was prepared for envelope simulation per the procedure given above. The equivalent circuit can be fed to any circuit simulator (we have used PSPICE) to carry out time domain (TRAN) simulation.

Once the time domain simulation is done, any of the envelope signals can be displayed. For example, the rms current of the lamp is

$$I_{\text{lampRMS}} = \sqrt{\frac{\{i(G_1)\}^2 + \{i(G_2)\}^2}{2}} \quad (22)$$

while the RMS voltage of the lamp is

$$V_{\text{lampRMS}} = \sqrt{\frac{\{v(\text{re})\}^2 + \{v(\text{im})\}^2}{2}}. \quad (23)$$

The plots of Fig. 5 demonstrate the excellent agreement between the proposed envelope simulation and cycle by cycle simulation (using in both cases the fluorescent lamp model [5]).

VI. SMALL-SIGNAL RESPONSE

To solve the problem of feedback loop design of a ballast-lamp system, we need the transfer function (v_{fb}/v_{err})(s) (Fig. 2). This can now be obtained by envelope simulation of the system. The transfer function is extracted by injecting a series of envelope signals and measuring the gain and phase. To test this proposed procedure, we examined the case of the

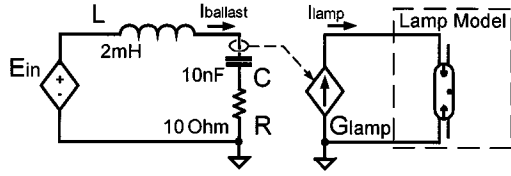

Fig. 11. Separated (tandem) scheme of ballast–lamp system (Fig. 9).

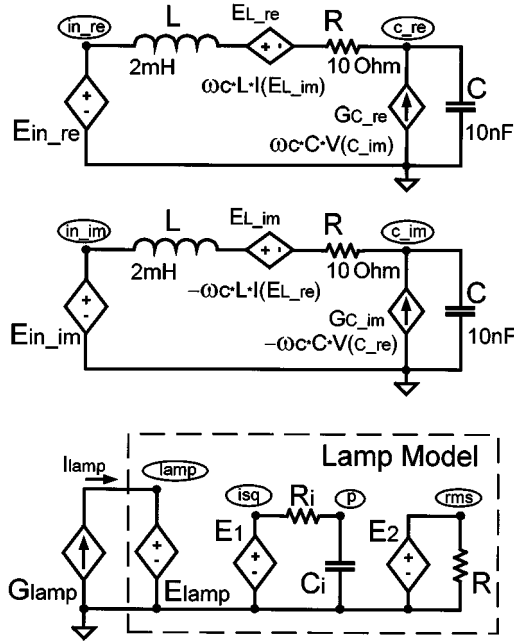

Fig. 12. Envelope simulation SPICE-compatible equivalent circuits of separated ballast–lamp system operating in open loop (Fig. 11).

Therefore, it is clear from Fig. 10, that the “loop gain” of the open-loop ballast lamp system is

$$\text{LoopGain} = \frac{1}{Z_{\text{ballast}}} \cdot Z_{\text{lamp}}. \quad (26)$$

This implies that one can examine the stability by, say, Nyquist plots of the function LoopGain. To this end, we can separate the two transfer functions: $1/Z_{\text{ballast}}$ and Z_{lamp} and put them in tandem (Fig. 11).

The “broken” network of Fig. 11 is always stable (the lamp is fed by a current source) so we can even examine by simulation cases in which the original ballast–lamp assembly is unstable. The original driver (Fig. 9) can be simulated (by normal cycle-by-cycle or envelope simulation) only if the system is stable. If the system is unstable, the simulator will fail to stabilize the system (of Fig. 9) at the desired operating point.

We demonstrate the proposed simulation method for the LoopGain by considering the envelope simulation SPICE-compatible equivalent circuits (Fig. 12) of separated ballast–lamp system (Fig. 11).

The simulation was done for the given RLC ballast–fluorescent lamp model topology (Fig. 9). The nominal ballast–lamp’s current was $0.34A_{\text{rms}}$ and

$$E_{\text{in_re}} \equiv A_m \cdot (1 + 0.05 \cdot \cos(2 \cdot \pi \cdot F_m \cdot t)) \quad (27)$$

$$E_{\text{in_im}} \equiv 0 \quad (28)$$

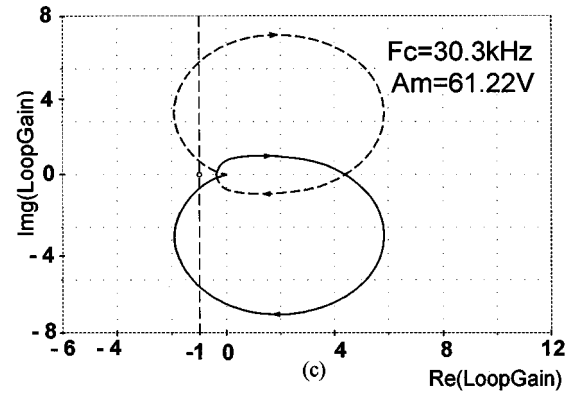
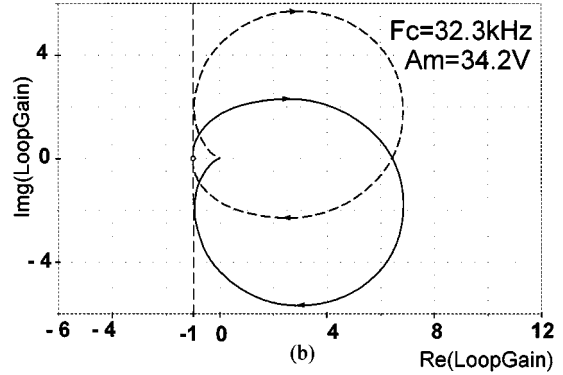
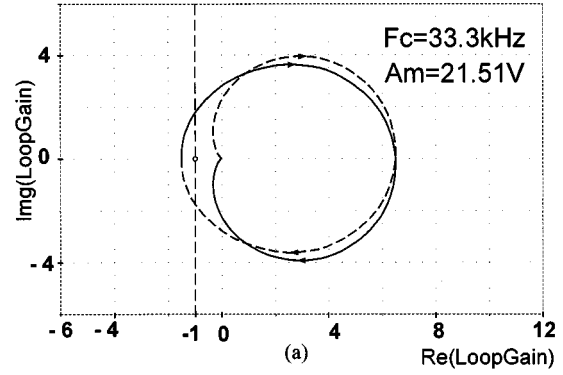
 Fig. 13. Nyquist plots of the LoopGain for different values of carrier frequency: (a) $F_c = 33.3$ kHz (b) $F_c = 32.3$ kHz. (c) $F_c = 30.3$ kHz.

$$G_{\text{lamp}} \equiv \sqrt{\{I(E_{L_re})\}^2 + \{I(E_{L_im})\}^2} \quad (29)$$

$$E_{\text{lamp}} \equiv I(E_{\text{lamp}}) \cdot \left(\frac{K_1}{v(\text{rms})} + K_2 + K_3 \cdot v(\text{rms}) \right). \quad (30)$$

The parameters of the fluorescent lamp model are the same as given in Section III.

The simulation was repeated for various values of excitation signal frequency. Amplitude value A_m of excitation signal (27) was adjusted to maintain the same lamp operating point in all runs. The results were used to generate Nyquist plots of the LoopGain function (Fig. 13).

The resonant frequency of the ballast under consideration (Fig. 9) is 35.5 kHz. At frequencies close to the resonant frequency the ballast represent low impedance and instability may occur. This can be observed in the simulation results. The system is unstable at 33.3 kHz [Fig. 13(a)], oscillatory at 32.3 kHz [Fig. 13(b)] and stable at 30.3 kHz [Fig. 13(c)].

To verify the results of envelope simulation (Fig. 13), we run cycle-by-cycle simulation of the complete ballast–lamp system (Fig. 9). It was found that the system was indeed stable for a carrier of 30.3 kHz and unstable for the other two cases.

VIII. DISCUSSION AND CONCLUSION

The results of this paper show that envelope simulation can be useful to obtain the small-signal response of a high frequency ballast–lamp system. Based on the open-loop gain and phase, the feedback path can be designed by classical frequency domain techniques. The validity of the proposed simulation method was verified against experimental results, showing that the simulation tool is reliable and simple to use. It is thus concluded that by applying the proposed simulation and design methodology, one can improve the performance of electronic ballasts by operating the system in closed-loop configuration while assuring dynamic stability.

The results of this paper further suggest that once the incremental impedance is taken into consideration, the necessity of having ballast with open-loop “current source” characteristics can be removed. That is, with properly designed feedback, the ballast–lamp system can be made stable in closed loop, even if it is unstable in open loop. This implies that stable ballasts can be designed with series elements of small impedances. Filaments preheating and lamp ignition can be achieved, in such cases, by adding a small series inductor and a small parallel capacitor. The parallel capacitor should be placed in series with the filaments as shown in Fig. 2. Start up conditions can be met by driving the system at frequency slightly above the (very high) series resonant frequency. The small series inductor will also help to reduce the EMI and help achieve soft switching.

REFERENCES

- [1] W. Elenbaas, Ed., *Fluorescent Lamps*. London, U.K.: Macmillan, 1971.
- [2] M. Gulko and S. Ben-Yaakov, “Current-sourcing parallel-resonant inverter (CS-PPRI): Theory and application as a fluorescent lamp driver,” in *Proc. IEEE APEC’93*, 1993, pp. 411–417.

- [3] E. Deng, “I. Negative incremental impedance of fluorescent lamp,” Ph.D. dissertation, California Institute of Technology, Pasadena, 1995.
- [4] E. Deng and S. Cuk, “Negative incremental impedance and stability of fluorescent lamp,” in *Proc. IEEE APEC’97*, 1997, pp. 1050–1056.
- [5] S. Ben-Yaakov, M. Shvartsas, and S. Glozman, “Statics and dynamics of fluorescent lamps operating at high frequency: Modeling and simulation,” in *Proc. IEEE APEC’99*, 1999, pp. 467–472.
- [6] S. Ben-Yaakov, S. Glozman, and R. Rabinovici, “Envelope simulation by SPICE compatible models of electric circuits driven by modulated signals,” *IEEE Trans. Ind. Electron.*, vol. 47, pp. 222–225, Feb. 2000.
- [7] C. T. Rim and G. H. Cho, “Phasor transformation and its application to the DC/AC analyzes of frequency phase-controlled series resonant converters (SRC),” *IEEE Trans. Power Electron.*, vol. 5, pp. 201–211, Apr. 1990.



Stanislav (Stas) Glozman was born in Tashkent, Uzbekistan, in 1972. He received the B.Sc. degree in electrical engineering in 1997 from Ben-Gurion University of the Negev, Beer-Sheva, Israel, where he is currently working toward the M.S. degree in electrical and computer engineering.

He is currently involved in a research program in the Power Electronics Group at Ben-Gurion University of the Negev. His fields of interest include fluorescent lamp modeling and electronic ballast design.



Shmuel (Sam) Ben-Yaakov (M’87) was born in Tel Aviv, Israel, in 1939. He received the B.Sc. degree in electrical engineering from the Technion, Haifa, Israel, and the M.S. and Ph.D. degrees in engineering from the University of California, Los Angeles, in 1961, 1967, and 1970, respectively.

He is currently a Professor in the Department of Electrical and Computer Engineering, Ben-Gurion University of the Negev, Beer-Sheva, Israel, where he heads the Power Electronics Group. He served as the Chairman of the department during the period 1985–1989. His current research interests include power electronics, circuits and systems, electronic instrumentation and engineering education. He also serves as a consultant to commercial companies on various subjects, including analog circuit design, modeling and simulation, PWM and resonant converters and inverters, soft-switching techniques, and electronic ballasts for discharge lamps.