

Method for expanding the uniformly shielded area in a short-length open-ended cylindrical magnetic shield

K. Oshita, I. Sasada,^{a)} H. Naka, and E. Paperno

Department of Applied Science for Electronics and Materials, Kyushu University, 6-1 Kasuga-Koen, Kasuga-Shi, Fukuoka 816-8580, Japan

A compensation method is proposed by which the uniformly shielded area of the axial magnetic field in a relatively short, open-structure axial magnetic shield can be extended. An open-ended cylindrical magnetic shield of 120 cm in length, 52 cm inner diameter, and a ~ 0.5 mm total thickness of the shielding material is used to demonstrate the idea. The shield axis is oriented along the horizontal component (~ 320 mG) of the Earth's magnetic field. A simple way to increase the axial shielding factor is to use a pair of compensating coaxial ring coils set at both open ends of the shield. This increases, however, the radial gradient of the shielded field since the axial compensation field is stronger towards the shield axis. In order to decrease the radial gradient, an additional ring coil is wound around the middle part of the outer surface of the shield. The compensating field generated by this central ring coil is stronger towards the inner surface of the shield, and it helps, therefore, to unify the axial resultant field over a wider area inside the shield. The axial shielding factor obtained with this compensation according to the proposed method is 128, in contrast to only 16.4 obtained with compensation by a set of two ring coils. The field gradients observed are $1.2 \mu\text{G}/\text{cm}$ along the length direction and $2.7 \mu\text{G}/\text{cm}$ along the radial direction, in contrast to the $14 \mu\text{G}/\text{cm}$ axial and $78 \mu\text{G}/\text{cm}$ radial gradients obtained with compensation by a set of two ring coils.

© 1999 American Institute of Physics. [S0021-8979(99)55508-4]

I. INTRODUCTION

Although completely closed magnetic shields can be generally considered as being more effective, technical and scientific applications frequently require shielding enclosures of an open structure. An example of such applications is a biomagnetic field measurement where an easy and free access to the shielded area is especially important. A short, open-ended cylindrical magnetic shield becomes a useful tool for weak magnetic field measurements, such as biomagnetic field measurements based on employment of superconducting quantum interference device (SQUID) gradiometers if its axial shielding factor is increased and the gradient of the residual field is acceptably reduced. It was shown previously that magnetic shaking allows the construction of relatively compact, lightweight, open-ended cylindrical magnetic shields that possess a large transverse shielding factor.¹ (The key to the magnetic shaking method is the use of soft magnetic materials with a highly rectangular $B-H$ loop and the application of a relatively high-frequency excitation magnetic field to them. The magnetic shaking mechanism can be explained as follows: the permeability seen for the external relatively slowly varying low-level magnetic field becomes high since the energy needed to move domain walls is mainly supplied by a fairly strong shaking field.) It was also already shown that active compensation for a transverse external field intruding into the shield through its open ends can provide a sufficiently small and uniform transverse back-

ground field, which enabled weak magnetic field measurements by SQUID gradiometers.² The magnetic shields described in Ref. 2 are designed to be placed in a horizontal position perpendicular to the ambient magnetic field, and, therefore, only their transverse shielding performance was investigated. Although magnetic shields employing magnetic shaking are relatively compact, available space does not always allow for locating them perpendicular to the Earth's magnetic field. Moreover, in the case of magnetoencephalography, a vertical design of an open-ended cylindrical shield would be more preferable than a horizontal design in order to accommodate relatively tall SQUID Dewars. Hence, there is a need to employ relatively short open-ended cylindrical shields to shield against axial magnetic fields. A fact well known from magnetic shielding theory states, however, that relatively short open-ended cylinders cannot be as effective in the axial direction as they are in the transverse direction.³ The effect of openings limits the axial shielding factors of even relatively high-permeability cylinders to less than several tens if their length-to-diameter ratio is about 2–2.5.³ It is evident, therefore, that active open-end compensation of the axial external field is needed to realize a large axial shielding factor and a low field gradient with relatively short, open-ended cylinders.

A simple way to increase the axial shielding factor is to use a pair of coaxial ring coils set at both open ends to deter the external field from intruding into the shield. However, a clear drawback of this approach is that the coil pair does not exactly simulate the profile of the magnetic field induced in the cylindrical shield by a uniform ambient field such as the

^{a)}Electronic mail: Sasada@ence.kyushu-u.ac.jp

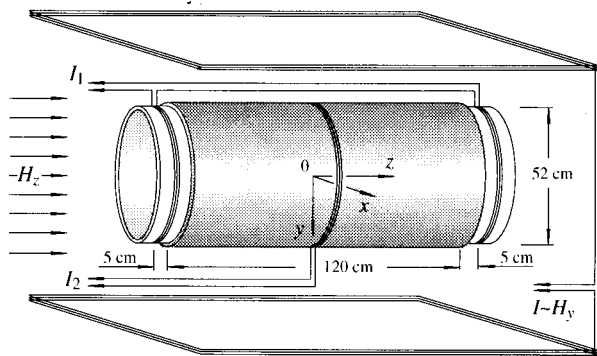

FIG. 1. Schematic layout of the shielding system.

Earth's magnetic field. The intensity of the compensation field grows when approaching the shield axis, and it increases the radial gradient of the shielded field. In order to improve this situation, the third ring coil is wound around the middle part of the outer surface of the shield in order to generate an axial compensating field with a distribution that is stronger towards the inner surface of the shield. The idea is that the current in the coil pair is tuned to cancel the radial gradient induced by the ring coil pair, thus unifying the field profile along the radial direction.

II. EXPERIMENTS

An open-ended cylindrical magnetic shield described in Ref. 4 was used for the experiments. The shield consists of five narrowly spaced shells of the same length (120 cm), which were made of Metglas 2705M amorphous tapes 5 cm wide and 22 μm thick. The tapes are wound around a tube having a 52 cm outer diameter. Three outer shells, each consisting of four layers of amorphous tape, carry a common toroidal shaking coil (50 turns). The fourth shell, consisting of eight layers of the tape, carries its own toroidal shaking coil (50 turns). The fifth, innermost shell, consisting of four amorphous tape layers, is not subjected to magnetic shaking but used to attenuate the leakage of the shaking field from the outer shells. The shield was placed horizontally, along the horizontal component of the Earth's magnetic field (320 mG).

Figure 1 shows the experimental setup. As one can see, the shield is supplied with a pair of coaxial ring coils located in the vicinity of its openings and carrying compensating

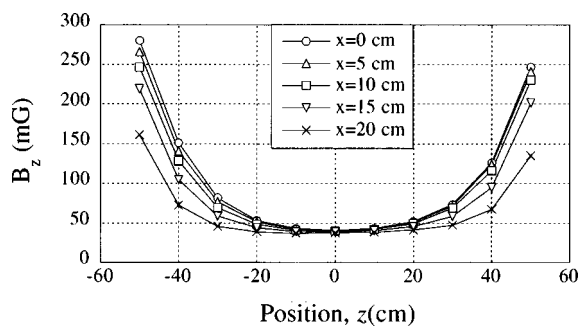

FIG. 2. Residual magnetic field measured along the shield axis taking radial position x as a parameter (compensation is off: $I_1=0$; $I_2=0$).

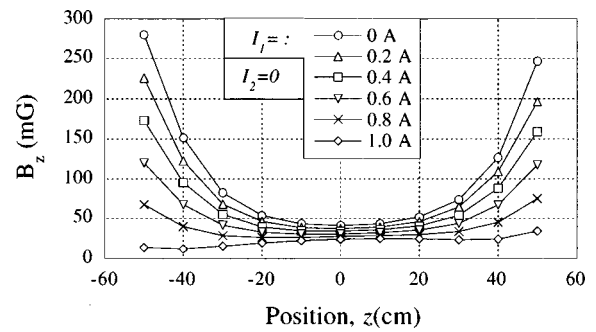

FIG. 3. Residual magnetic field measured along the shield axis taking compensating current, I_1 through the ring coil pair as a parameter.

current I_1 . A large Helmholtz coil is used to apply a transverse magnetic field to the shield when the transverse shielding factor is monitored. The amplitude of the electric current in the shaking coils was set to 35 mA at 200 Hz. Profiles of the residual magnetic field measured along the shield axis, z , without applying any compensation are shown in Fig. 2, taking the radial position x as a parameter. The residual magnetic field of 41 mG, measured at the shield center, results in an axial shielding factor of only 8.

Figure 3 shows results of compensating the residual magnetic field by using the ring coil pair. Profiles of the residual magnetic field measured along the shield axis for a series of I_1 values are shown. It is found that the gradient of the residual field observed along the shield axis can be effectively reduced by adjusting the current I_1 to ~ 0.8 A. One can see, however, that the value of the residual magnetic field near the shield center still remains far above zero. While increasing compensation current I_1 above ~ 0.8 A, the axial gradient starts to develop in the opposite direction. This demonstrates that the compensation field provided by the ring coil pair is not able to simulate the magnetic field induced in the shield by a uniform ambient magnetic field exactly.

It is also important to compensate the axial gradient of the shielded field. Figure 4 shows the distribution of the residual field measured in different positions along the x axis in the middle of the shield ($z=0$). One can see that without compensation or with only a small compensating current, the residual magnetic field is largest when $x=0$ and decreases with an increase in the x coordinate. With increasing I_1 , the residual field reaches a uniform distribution. This happened because the compensating field provided by the ring coil pair

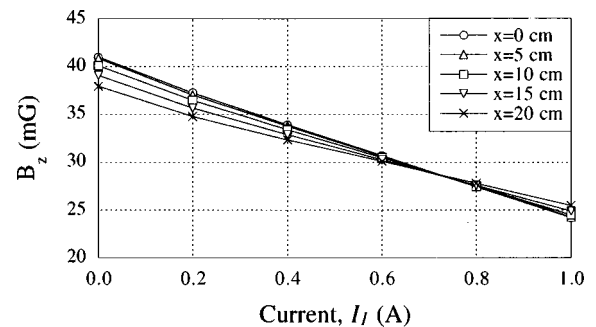

FIG. 4. Residual magnetic field measured along the shield axis vs compensating current, I_2 through the ring coil pair ($I_2=0$).

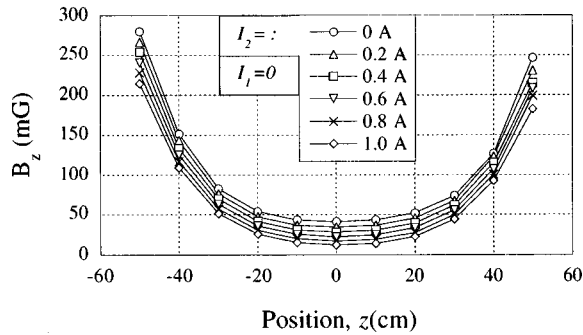

FIG. 5. Residual magnetic field measured along the shield axis taking compensating current, I_2 through an additional ring coil as a parameter.

is stronger along the shield axis and gradually decreases towards the inner surface of the shield. Although compensating current, $I_1 \approx 0.7$ A, provides a uniform distribution of the residual magnetic field, it is found that the remaining residual field level is still large.

By a close inspection of the relationship between the residual magnetic field and the compensating current, I_1 above ~ 0.7 A in Fig. 4, one may consider using an additional compensation coil, providing a stronger field near the inner surface of the shield in order to cancel the radial gradient introduced by the ring coil pair. As a coil to satisfy the above condition, we chose a ring coil wound around the central part of the outer surface of the shield, one carrying electric current I_2 (see Fig. 1). Figure 5 shows the residual magnetic field distribution measured along the shield axis when compensation by the central ring coil is employed. Figure 6 shows the radial distribution of the residual magnetic field in the middle of the shield ($z=0$) versus compensating current, I_2 . By comparing Figs. 4 and 6, one can see that the radial gradient developed by the central coil is comparable, but with an opposite sign, to the radial gradient developed by the ring coil pair if $I_1 > 0.72$ A. Hence, simultaneous employment of both coil sets effectively reduces the radial gradient and improves the uniformity of the residual field while keeping the gradient along the axial direction almost unchanged. Further, the level of the residual field is also reduced due to the above proposed compensation.

An essential issue that remains is to find the right combination of the two compensating currents, I_1 and I_2 , for a given external axial magnetic field. In the present work, however, we only confirm the usefulness of the proposed

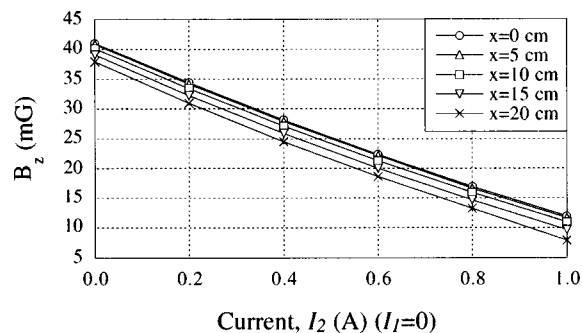

FIG. 6. Residual magnetic field measured along the shield axis vs compensating current, I_2 , through additional single coil ($I_1=0$).

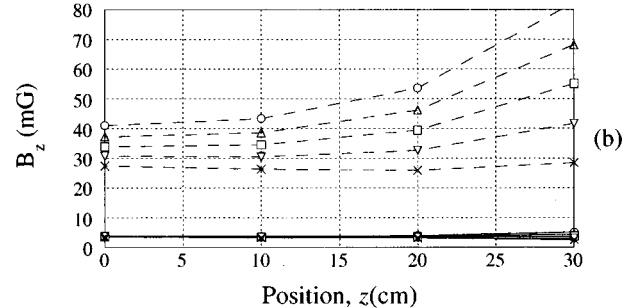
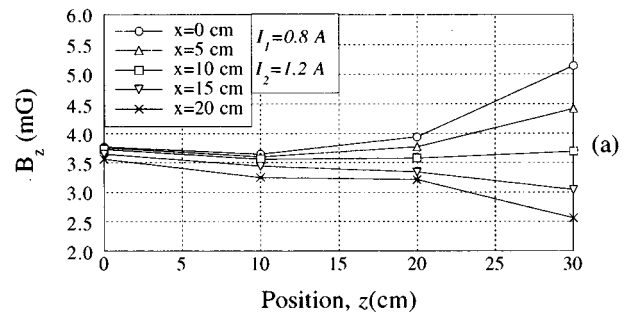

FIG. 7. Effectiveness of the proposed method. (a) Residual magnetic field measured along the shield axis taking radial position x as a parameter (compensation is on: $I_1=0.8$ A; $I_2=1.2$ A). (b) A comparison between the data shown in Fig. 2 (the dashed curves) and (a).

method, adopting the procedure in which the current for the ring coil pair is first adjusted so that the residual magnetic field distribution along the shield axis is as uniform as possible and then the current in the center ring coil is adjusted to make the radial gradient zero. The results obtained with this procedure are shown in Fig. 7.

Another important factor is to confirm that the transverse shielding performance of the shield is not reduced due to possible saturation of the shielding material by a relatively large magnetic field generated by the central compensating coil. This was tested by applying a transverse (y direction in Fig. 1) magnetic field of 100 mG at 10 Hz using a large Helmholtz coil. The shield axis in this experiment was set parallel to the horizontal component of the Earth's magnetic field. The experiment revealed that the transverse shielding factor was also increased with the compensations on, in which the shielding factor of 323 without compensation grew to 578 with the compensations on.

III. CONCLUSIONS

A method for compensating axial magnetic field for a relatively short cylindrical shield with both ends open is shown to be effective to obtain a low residual field and low gradient at the same time. An important practical aspect of the proposed method is that all the compensating coils are installed outside the shield, leaving the shielded area free of additional constructing elements.

¹I. Sasada, S. Kubo, and K. Harada, J. Appl. Phys. **64**, 5696 (1988).
²I. Sasada and Y. Oonaka, J. Appl. Phys. **75**, 6984 (1994).
³A. Mager, IEEE Trans. Magn. **6**, 67 (1970).
⁴I. Sasada, T. Yamamoto, and Y. Yamauchi, J. Appl. Phys. **79**, 5490 (1996).